

## LOW POWER QUAD OPERATIONAL AMPLIFIERS

- LARGE VOLTAGE GAIN : 100dB
- VERY LOW SUPPLY CURRENT/AMPLI : 375 $\mu$ A
- LOW INPUT BIAS CURRENT : 20nA
- LOW INPUT OFFSET VOLTAGE : 2mV
- LOW INPUT OFFSET CURRENT : 2nA
- WIDE POWER SUPPLY RANGE :  
SINGLE SUPPLY : +3V TO +30V  
DUAL SUPPLIES :  $\pm$ 1.5V TO  $\pm$ 15V

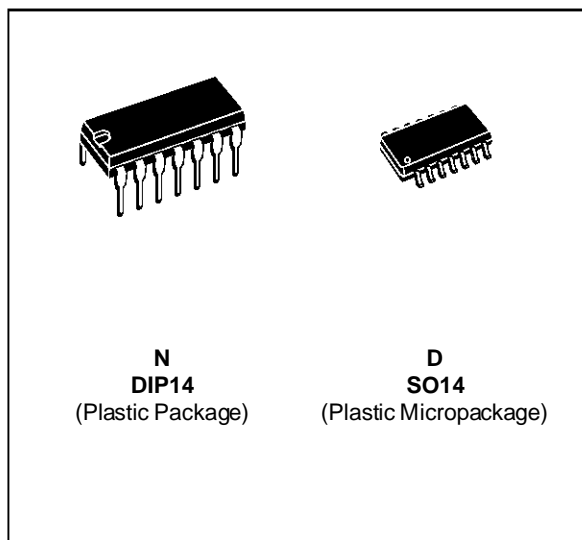

### DESCRIPTION

These circuits consist of four independent, high gain, internally frequency compensated operational amplifiers which were designed specifically for automotive and industrial control systems. They operate from a single power supply over a wide range of voltages. Operation from split power supplies is also possible and the low power supply current drain is independent of the magnitude of the power supply voltage.

### ORDER CODES

Part Number	Temperature Range	Package	
		N	D
LM124,A	-55°C, +125°C	•	•
LM224,A	-40°C, +105°C	•	•
LM324,A	0°C, +70°C	•	•

**Example : LM224N**

124-01.TBL

### PIN CONNECTIONS (top view)

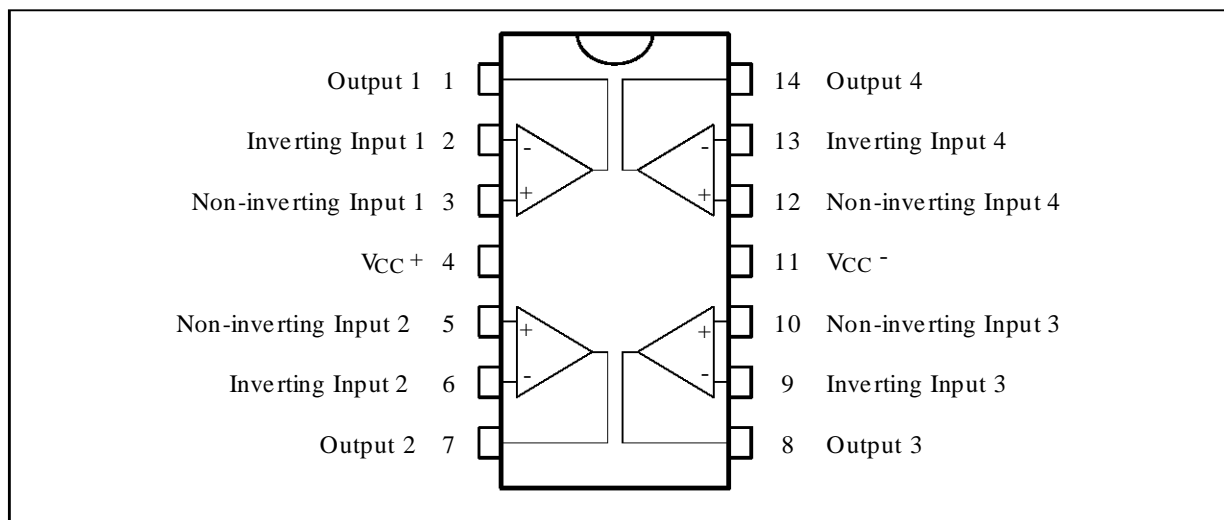

124-01.EPS

**SCHEMATIC DIAGRAM (1/4 LM124)**

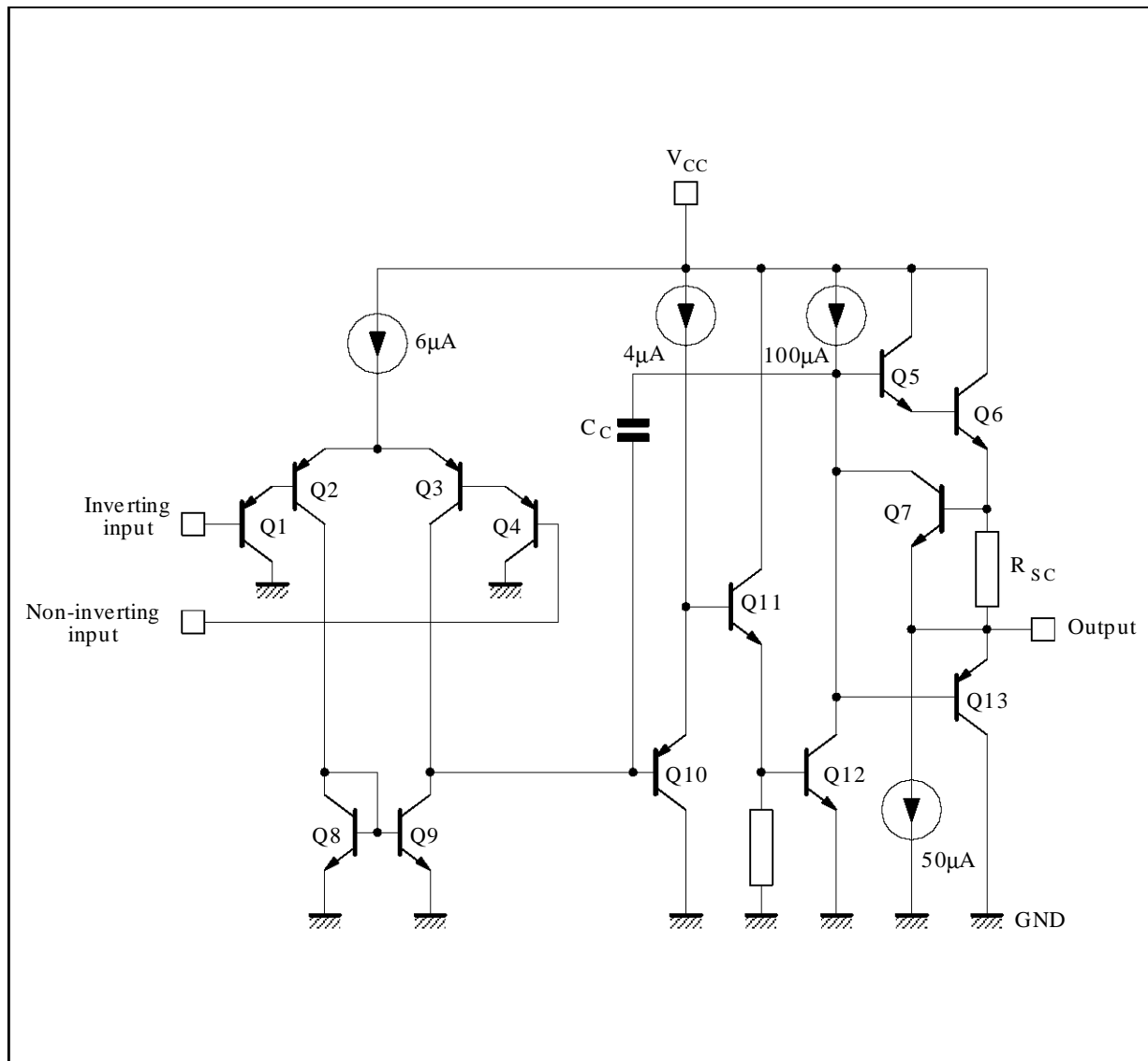

124-02.EPS

**ABSOLUTE MAXIMUM RATINGS**

Symbol	Parameter	LM124,A	LM224,A	LM324,A	Unit
$V_{cc}$	Supply Voltage	±16 or 32			V
$V_i$	Input Voltage	-0.3 to +32			V
$V_{id}$	Differential Input Voltage - (*)	+32	+32	+32	V
$P_{tot}$	Power Dissipation	N Suffix 500	D Suffix 400	500 400	mW mW
-	Output Short-circuit Duration - (note 1)	Infinite			
$I_{in}$	Input Current - (note 6)	50	50	50	mA
$T_{oper}$	Operating Free Air Temperature Range	-55 to +125	-40 to +105	0 to +70	°C
$T_{stg}$	Storage Temperature Range	-65 to +150	-65 to +150	-65 to +150	°C

(\*) - Either or both input voltages must not exceed the magnitude of  $V_{cc}^+$  or  $V_{cc}^-$ .

124-02.TBL

**ELECTRICAL CHARACTERISTICS**

$V_{CC}^+ = +5V$ ,  $V_{CC}^- = \text{Ground}$ ,  $V_O = 1.4V$ ,  $T_{amb} = +25^\circ C$   
(unless otherwise specified)

Symbol	Parameter	LM124A - LM224A LM324A			LM124 - LM224 LM324			Unit
		Min.	Typ.	Max.	Min.	Typ.	Max.	
$V_{io}$	Input Offset Voltage (note 3) $T_{amb} = +25^\circ C$ $T_{min.} \leq T_{amb} \leq T_{max.}$ LM324 LM324		2	3 5		2	5 7 9	mV
$I_{io}$	Input Offset Current $T_{amb} = +25^\circ C$ $T_{min.} \leq T_{amb} \leq T_{max.}$		2	10 30		2	30 100	nA
$I_{ib}$	Input Bias Current (note 2) $T_{amb} = +25^\circ C$ $T_{min.} \leq T_{amb} \leq T_{max.}$		20	50 100		20	150 300	nA
$A_{vd}$	Large Signal Voltage Gain ( $V_{CC}^+ = +15V$ , $R_L = 2k\Omega$ , $V_O = 1.4V$ to $11.4V$ ) $T_{amb} = +25^\circ C$ $T_{min.} \leq T_{amb} \leq T_{max.}$	50 25	100		50 25	100		V/mV
SVR	Supply Voltage Rejection Ratio ( $R_s \leq 10k\Omega$ ) ( $V_{CC}^+ = 5V$ to $30V$ ) $T_{amb} = +25^\circ C$ $T_{min.} \leq T_{amb} \leq T_{max.}$	65 65	110		65 65	110		dB
$I_{CC}$	Supply Current, all Amp, no load $T_{amb} = +25^\circ C$ $T_{min.} \leq T_{amb} \leq T_{max.}$ $V_{CC} = +5V$ $V_{CC} = +30V$ $V_{CC} = +5V$ $V_{CC} = +30V$		0.7 1.5 0.8 1.5	1.2 3 1.2 3		0.7 1.5 0.8 1.5	1.2 3 1.2 3	mA
$V_{icm}$	Input Common Mode Voltage Range ( $V_{CC} = +30V$ ) - (note 4) $T_{amb} = +25^\circ C$ $T_{min.} \leq T_{amb} \leq T_{max.}$	0 0		$V_{CC} - 1.5$ $V_{CC} - 2$	0 0		$V_{CC} - 1.5$ $V_{CC} - 2$	V
CMR	Common-mode Rejection Ratio ( $R_s \leq 10k\Omega$ ) $T_{amb} = +25^\circ C$ $T_{min.} \leq T_{amb} \leq T_{max.}$	70 60	80		70 60	80		dB
$I_{source}$	Output Current Source ( $V_{id} = +1V$ ) $V_{CC} = +15V$ , $V_O = +2V$	20	40		20	40		mA
$I_{sink}$	Output Sink Current ( $V_{id} = -1V$ ) $V_{CC} = +15V$ , $V_O = +2V$ $V_{CC} = +15V$ , $V_O = +0.2V$	10 12	20 50		10 12	20 50		mA $\mu A$
$I_o$	Short Circuit to Ground $V_{CC} = +15V$		40	60		40	60	mA

124-03.TBL

ELECTRICAL CHARACTERISTICS (continued)

Symbol	Parameter	LM124A - LM224A LM324A			LM124 - LM224 LM324			Unit
		Min.	Typ.	Max.	Min.	Typ.	Max.	
V <sub>OH</sub>	High Level Output Voltage (V <sub>CC</sub> = +30V) T <sub>amb</sub> = +25°C T <sub>min.</sub> ≤ T <sub>amb</sub> ≤ T <sub>max.</sub> R <sub>L</sub> = 2kΩ T <sub>amb</sub> = +25°C T <sub>min.</sub> ≤ T <sub>amb</sub> ≤ T <sub>max.</sub> R <sub>L</sub> = 10kΩ (V <sub>CC</sub> = +5V, R <sub>L</sub> = 2kΩ) T <sub>amb</sub> = +25°C T <sub>min.</sub> ≤ T <sub>amb</sub> ≤ T <sub>max.</sub>	26	27		26	27		V
		26			26			
		27	28		27	28		
		27			27			
V <sub>OL</sub>	Low Level Output Voltage (R <sub>L</sub> = 10kΩ) T <sub>amb</sub> = +25°C T <sub>min.</sub> ≤ T <sub>amb</sub> ≤ T <sub>max.</sub>		5	20		5	20	mV
				20			20	
SR	Slew Rate (V <sub>CC</sub> = 15V, V <sub>I</sub> = 0.5 to 3V, R <sub>L</sub> = 2kΩ, C <sub>L</sub> = 100pF, T <sub>amb</sub> = +25°C, unity gain)		0.4			0.4		V/μs
GBP	Gain Bandwidth Product (V <sub>CC</sub> = 30V f = 100kHz, T <sub>amb</sub> = +25°C, V <sub>in</sub> = 10mV R <sub>L</sub> = 2kΩ, C <sub>L</sub> = 100pF)		1.3			1.3		MHz
THD	Total Harmonic Distortion (f = 1kHz, A <sub>V</sub> = 20dB, R <sub>L</sub> = 2kΩ, V <sub>O</sub> = 2V <sub>pp</sub> C <sub>L</sub> = 100pF, T <sub>amb</sub> = +25°C, V <sub>CC</sub> = 30V)		0.015			0.015		%
e <sub>n</sub>	Equivalent Input Noise Voltage (f = 1kHz, R <sub>s</sub> = 100Ω, V <sub>CC</sub> = 30V)		40			40		$\frac{nV}{\sqrt{Hz}}$
DV <sub>io</sub>	Input Offset Voltage Drift		7	30		7	30	μV/°C
DI <sub>io</sub>	Input Offset Current Drift		10	200		10	200	pA/°C
V <sub>O1</sub> /V <sub>O2</sub>	Channel Separation (note 5) 1kHz ≤ f ≤ 20kHz		120			120		dB

- Notes :**
- Short-circuits from the output to V<sub>CC</sub> can cause excessive heating if V<sub>CC</sub> > 15V. The maximum output current is approximately 40mA independent of the magnitude of V<sub>CC</sub>. Destructive dissipation can result from simultaneous short-circuit on all amplifiers.
  - The direction of the input current is out of the IC. This current is essentially constant, independent of the state of the output so no loading change exists on the input lines.
  - V<sub>o</sub> = 1.4V, R<sub>s</sub> = 0Ω, 5V < V<sub>CC</sub> < 30V, 0 < V<sub>ic</sub> < V<sub>CC</sub> - 1.5V
  - The input common-mode voltage of either input signal voltage should not be allowed to go negative by more than 0.3V. The upper end of the common-mode voltage range is V<sub>CC</sub> - 1.5V, but either or both inputs can go to +32V without damage.
  - Due to the proximity of external components insure that coupling is not originating via stray capacitance between these external parts. This typically can be detected as this type of capacitance increases at higher frequencies.
  - This input current only exists when the voltage at any of the input leads is driven negative. It is due to the collector-base junction of the input PNP transistor becoming forward biased and thereby acting as input diodes clamps. In addition to this diode action, there is also NPN parasitic action on the IC chip. this transistor action can cause the output voltages of the Op-amps to go to the V<sub>CC</sub> voltage level (or to ground for a large overdrive) for the time duration than an input is driven negative.  
This is not destructive and normal output will set up again for input voltage higher than -0.3V.

124-04.TEL

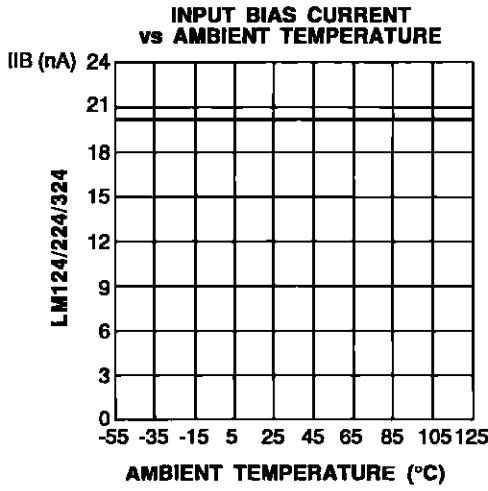

124-03.EPS

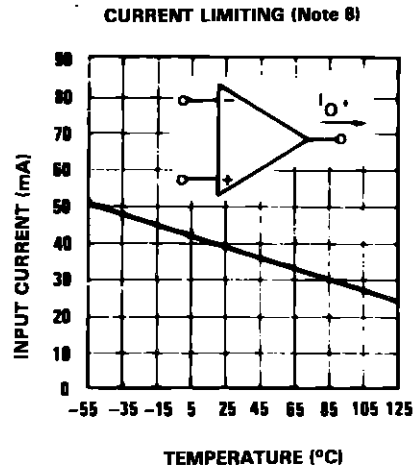

124-04.EPS

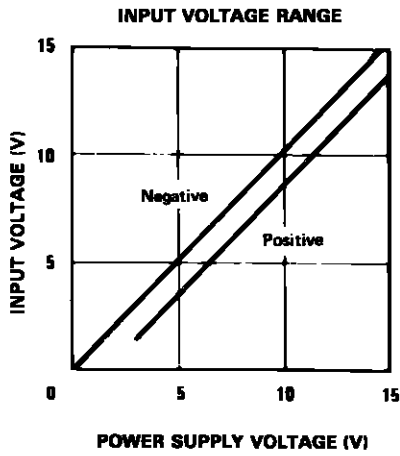

124-05.EPS

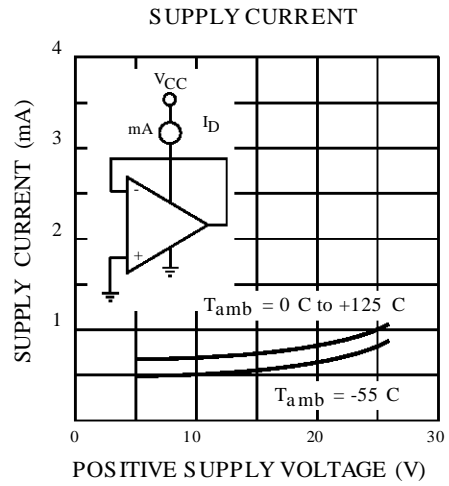

124-06.EPS

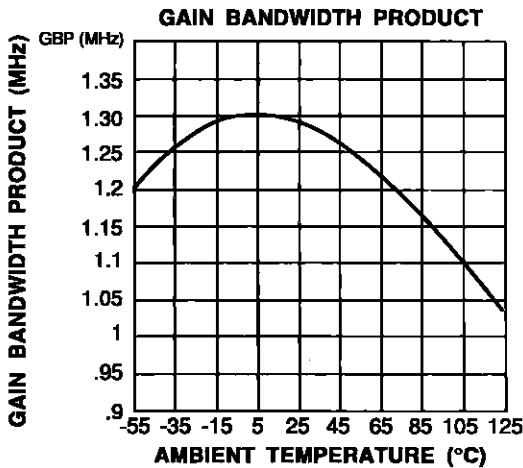

124-07.EPS

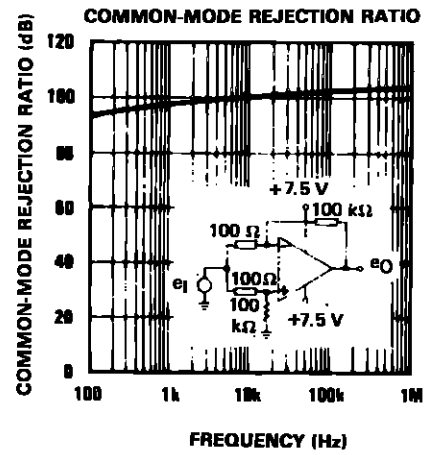

124-08.EPS

OPEN LOOP FREQUENCY RESPONSE

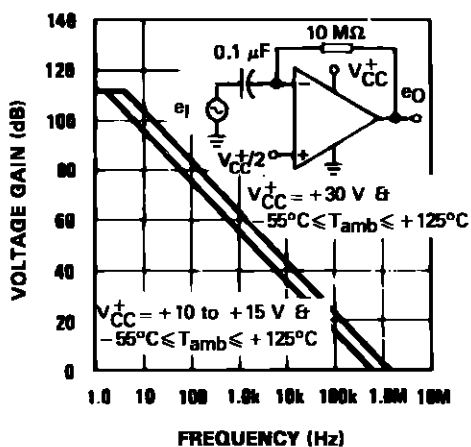

LARGE SIGNAL FREQUENCY RESPONSE

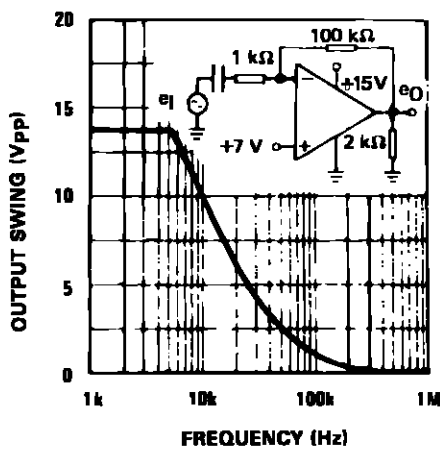

VOLTAGE FOLLOWER PULSE RESPONSE

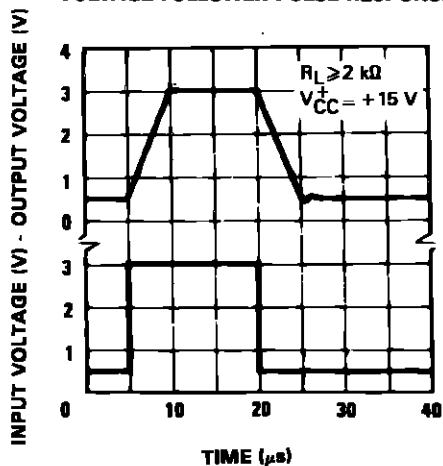

OUTPUT CHARACTERISTICS (CURRENT SINKING)

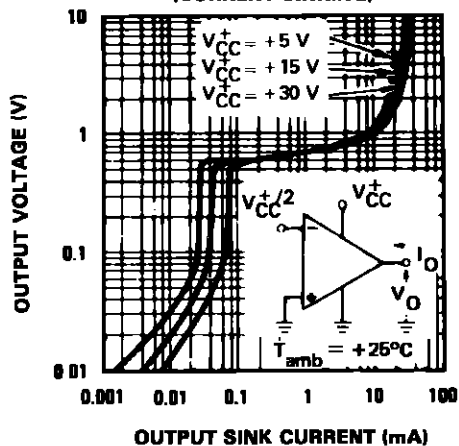

VOLTAGE FOLLOWER PULSE RESPONSE (SMALL SIGNAL)

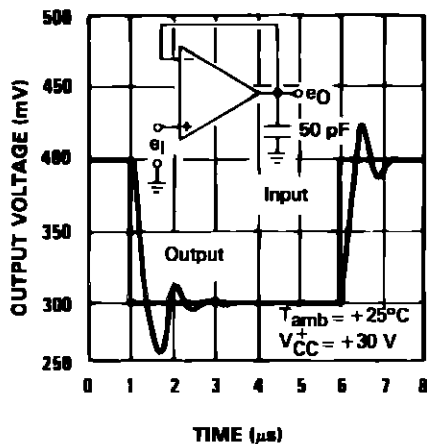

OUTPUT CHARACTERISTICS (CURRENT SOURCING)

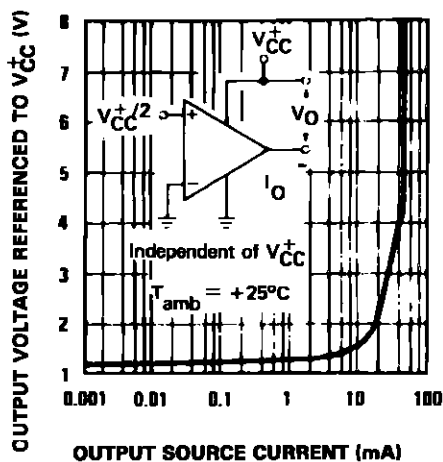

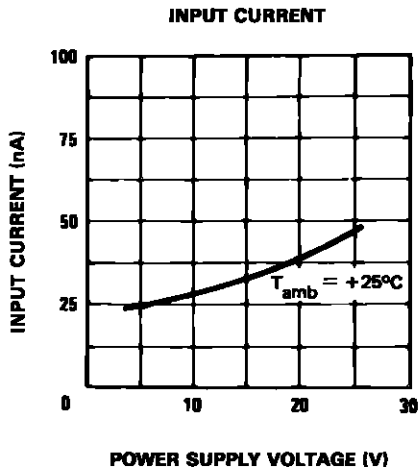

124-10.EPS

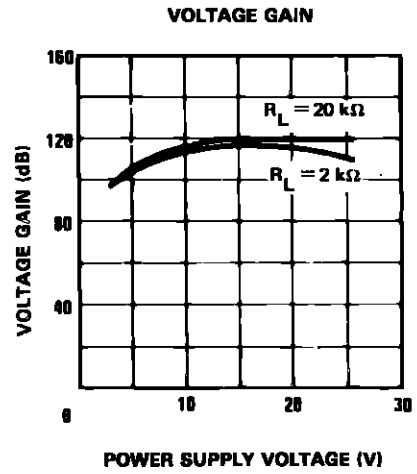

124-11.EPS

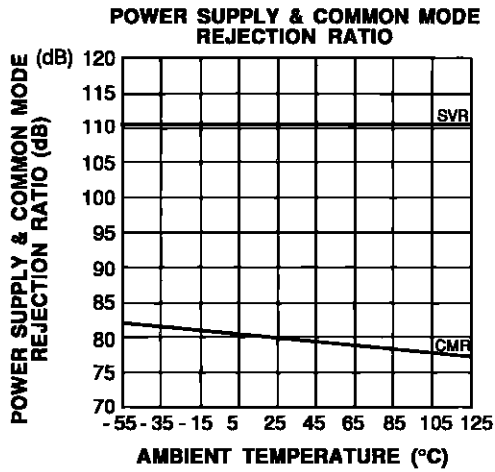

124-12.EPS

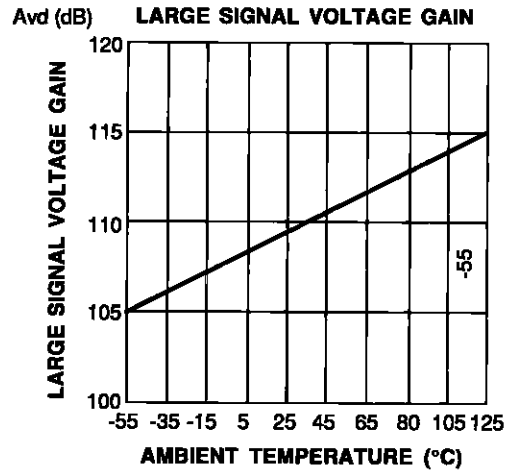

124-13.EPS

**TYPICAL SINGLE - SUPPLY APPLICATIONS**  
AC COUPLED INVERTING AMPLIFIER

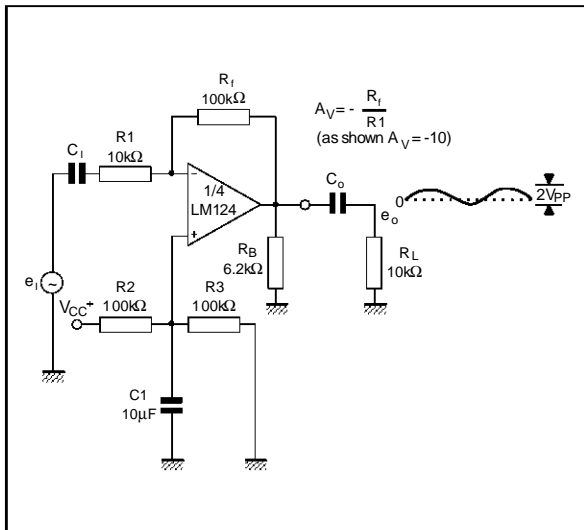

124-14.EPS

AC COUPLED NON-INVERTING AMPLIFIER

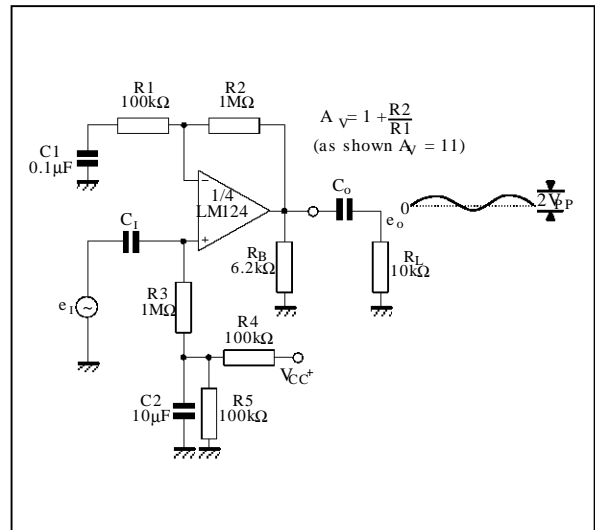

124-15.EPS

TYPICAL SINGLE - SUPPLY APPLICATIONS

NON-INVERTING DC GAIN

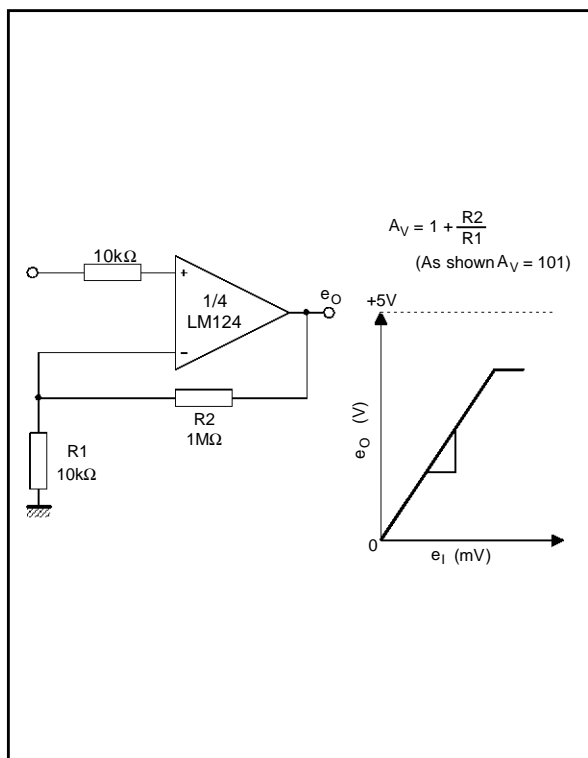

DC SUMMING AMPLIFIER

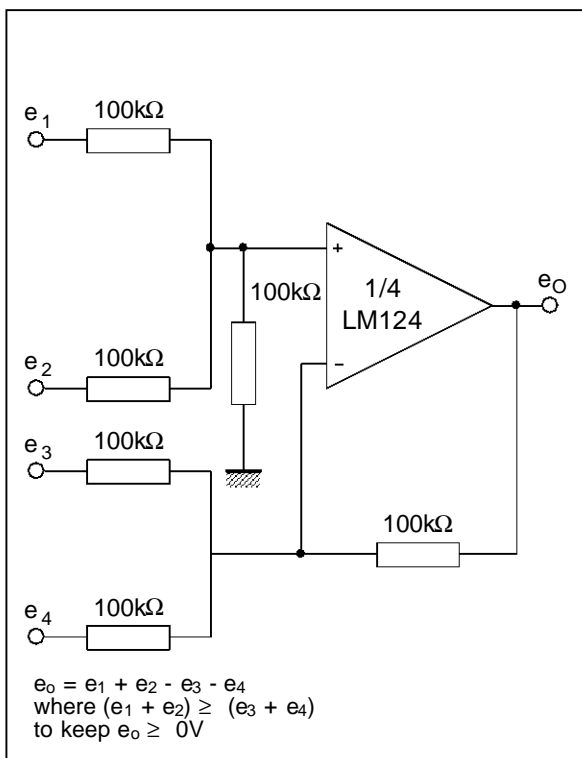

HIGH INPUT Z ADJUSTABLE GAIN DC INSTRUMENTATION AMPLIFIER

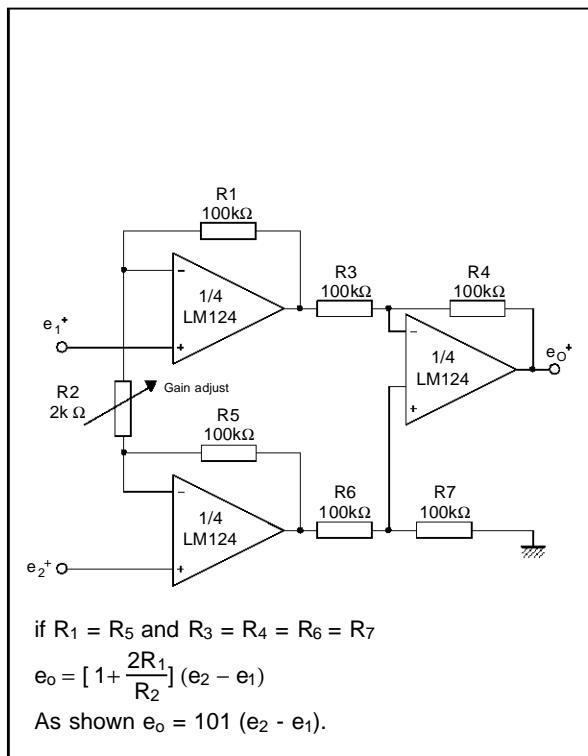

LOW DRIFT PEAK DETECTOR

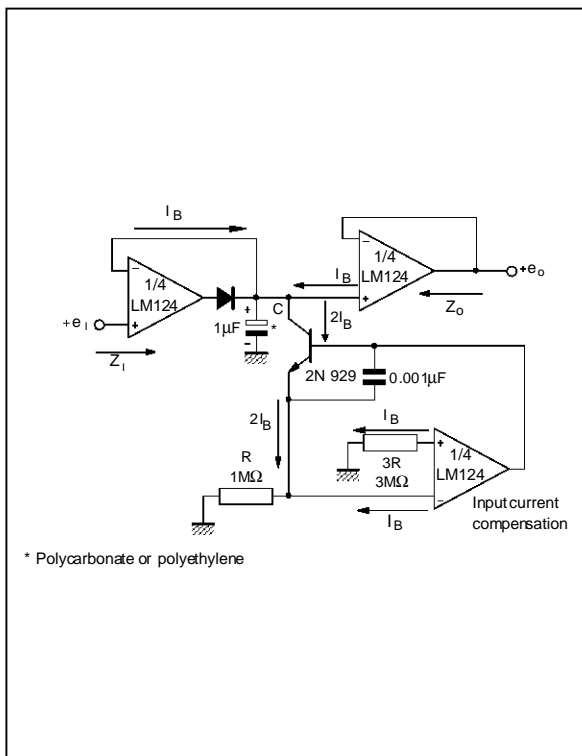



TYPICAL SINGLE - SUPPLY APPLICATIONS

ACTIVER BANDPASS FILTER

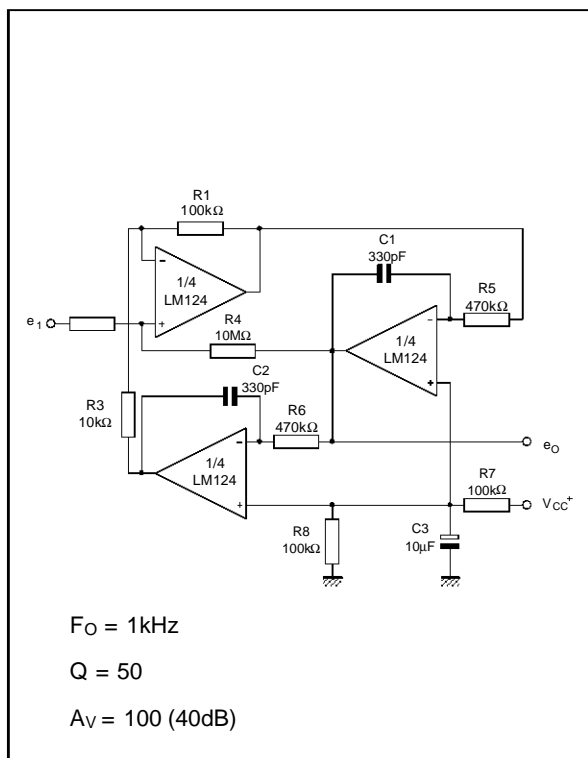

HIGH INPUT Z, DC DIFFERENTIAL AMPLIFIER

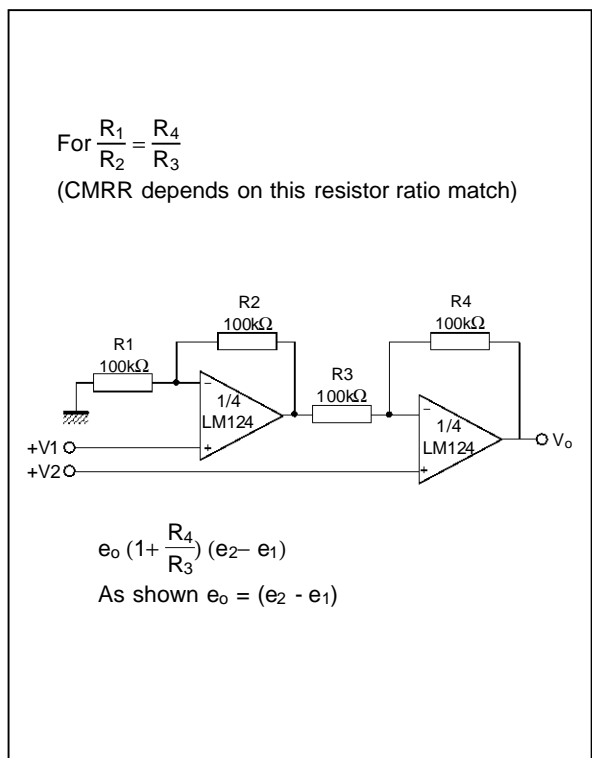

USING SYMMETRICAL AMPLIFIERS TO REDUCE INPUT CURRENT (GENERAL CONCEPT)

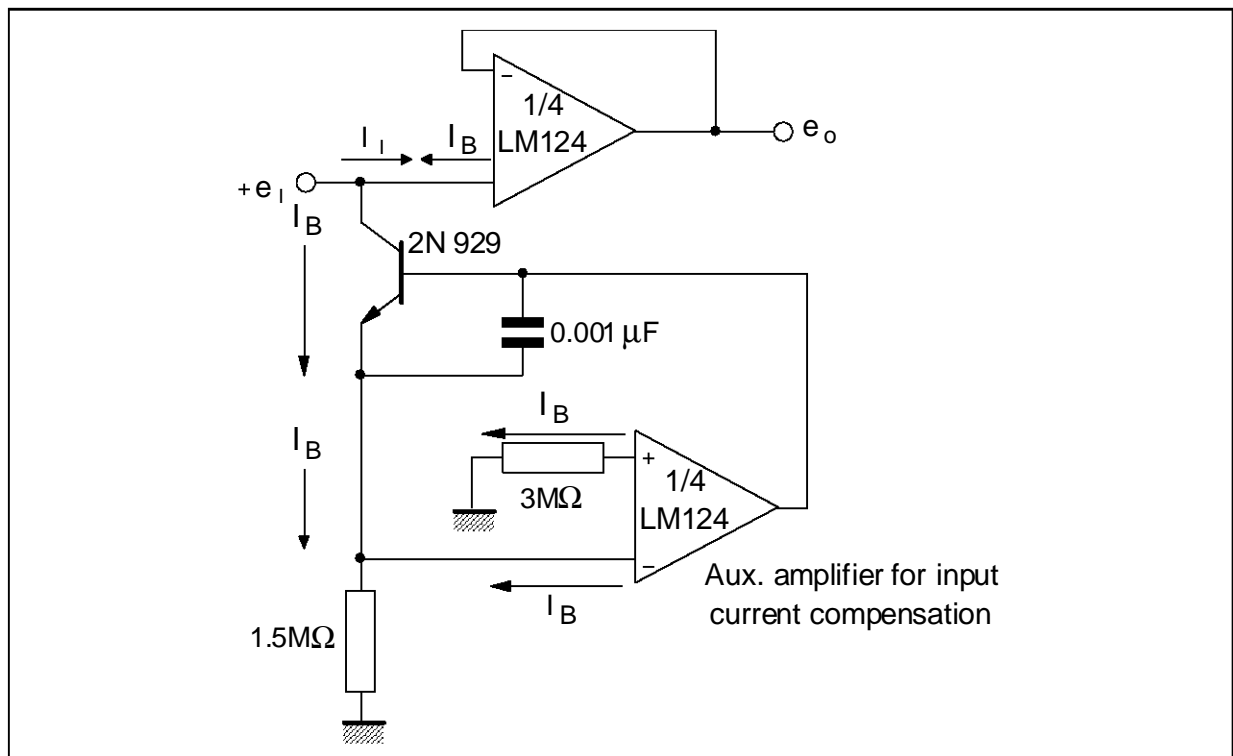

**PACKAGE MECHANICAL DATA**  
14 PINS - PLASTIC DIP OR CERDIP

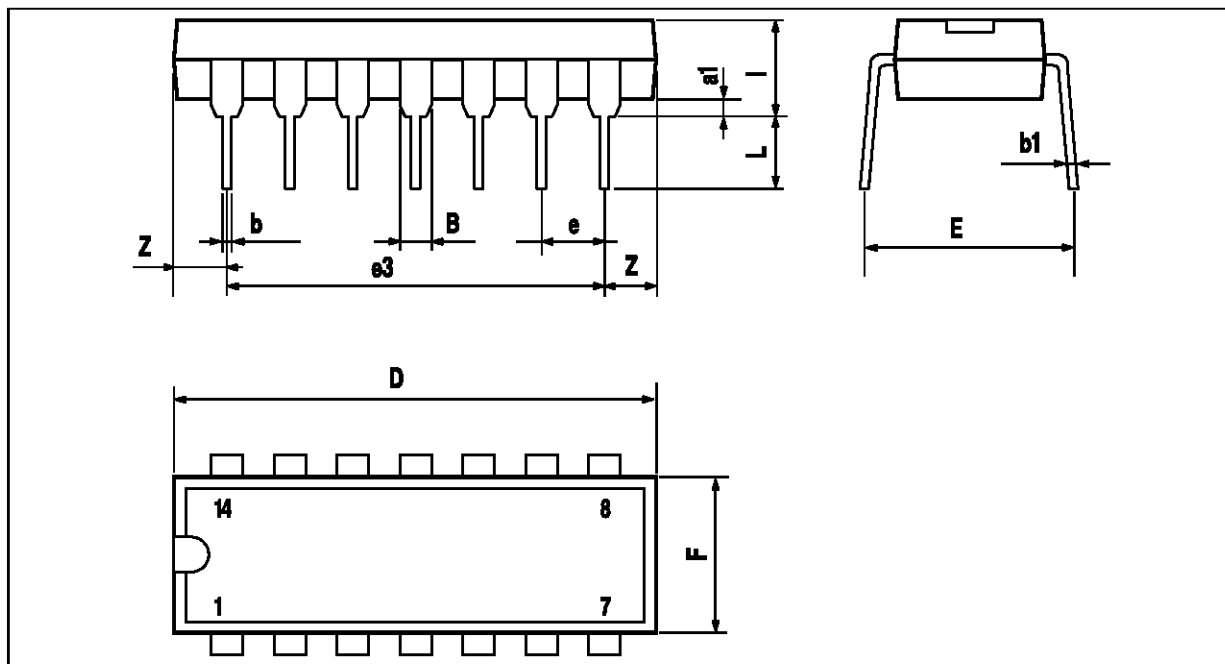

PM-DIP14.EPS

Dimensions	Millimeters			Inches		
	Min.	Typ.	Max.	Min.	Typ.	Max.
a1	0.51			0.020		
B	1.39		1.65	0.055		0.065
b		0.5			0.020	
b1		0.25			0.010	
D			20			0.787
E		8.5			0.335	
e		2.54			0.100	
e3		15.24			0.600	
F			7.1			0.280
i			5.1			0.201
L		3.3			0.130	
Z	1.27		2.54	0.050		0.100

DIP14.TBL

**PACKAGE MECHANICAL DATA**  
14 PINS - PLASTIC MICROPACKAGE (SO)

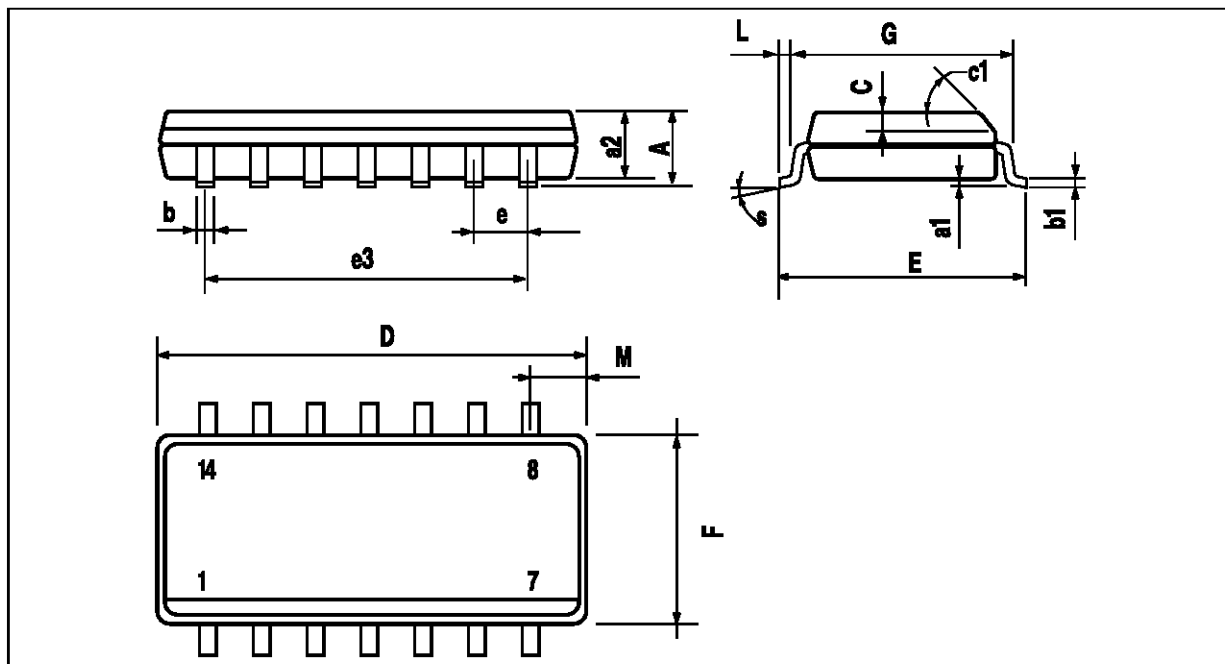

PM-S014.EPS

Dimensions	Millimeters			Inches		
	Min.	Typ.	Max.	Min.	Typ.	Max.
A			1.75			0.069
a1	0.1		0.2	0.004		0.008
a2			1.6			0.063
b	0.35		0.46	0.014		0.018
b1	0.19		0.25	0.007		0.010
C		0.5			0.020	
c1	45° (typ.)					
D	8.55		8.75	0.336		0.334
E	5.8		6.2	0.228		0.244
e		1.27			0.050	
e3		7.62			0.300	
F	3.8		4.0	0.150		0.157
G	4.6		5.3	0.181		0.208
L	0.5		1.27	0.020		0.050
M			0.68			0.027
S	8° (max.)					

SO14.TBL

Information furnished is believed to be accurate and reliable. However, SGS-THOMSON Microelectronics assumes no responsibility for the consequences of use of such information nor for any infringement of patents or other rights of third parties which may result from its use. No license is granted by implication or otherwise under any patent or patent rights of SGS-THOMSON Microelectronics. Specification mentioned in this publication are subject to change without notice. This publication supersedes and replaces all information previously supplied. SGS-THOMSON Microelectronics products are not authorized for use as critical components in life support devices or systems without express written approval of SGS-THOMSON Microelectronics.

© 1996 SGS-THOMSON Microelectronics – Printed in Italy – All Rights Reserved

SGS-THOMSON Microelectronics GROUP OF COMPANIES  
Australia - Brazil - Canada - China - France - Germany - Hong Kong - Italy - Japan - Korea - Malaysia - Malta - Morocco  
The Netherlands - Singapore - Spain - Sweden - Switzerland - Taiwan - Thailand - United Kingdom - U.S.A.

ORDER CODE :